

# Vacuum Pump Inlet & Exhaust Filters

## Balston Vacuum Pump Filters

Balston Vacuum Pump Exhaust Filters remove 99.9% of 0.1 micron oil mist and smoke particles. Balston Grade 30 Vacuum Pump Inlet Filters remove 90% of all 0.1 micron particles and droplets. Balston Grade 102 Vacuum Pump Inlet Filters prevent oil backstreaming from the pump to the evacuated chamber, and protect the pump from damage by submicron particles (at relatively low concentrations).

All Balston filters are available for hazardous and non-hazardous applications, and offer superior chemical and solvent resistance. Balston Vacuum Pump Filters increase productivity by eliminating costly shutdown time and maintenance.



## Product Features

- Exhaust filters eliminate oil mist and smoke from vacuum pump exhaust
- Prevent oil backstreaming
- Prevent oil accumulation in ductwork
- Protect vacuum pumps and reduce costly maintenance
- Easy to install and maintain

Small Scale Laboratory Vacuum Pumps



Specialized Vacuum Electronics Manufacturing

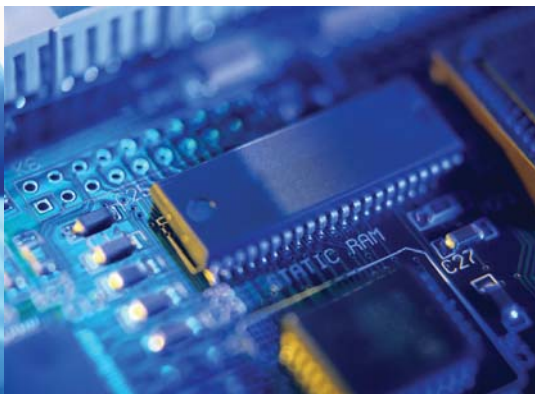

High Volume Vacuum for Process Packaging



# Vacuum Pump Inlet & Exhaust Filters

## Exhaust Filters for Hazardous/Corrosive Applications

Eliminate 99.9% oil mist and smoke from vacuum pump exhaust

Prevent oil accumulation in ductwork

Recover expensive lubricating oils, and automatically return filtered oil to pump

Eliminate potential OSHA and EPA violations



CV-0118

Vacuum Pump Filters

### Balston Vacuum Pump Exhaust Filters

Balston Vacuum Pump Exhaust Filters remove all visible oil mist and smoke from vacuum pump exhaust, even when it is saturated with oil. The high efficiency filter cartridge continuously drains the collected liquid, allowing the user to recover expensive lubricating fluid.

#### How To Select The Filter

For most applications, simply select the filter assembly which has a flow capacity equal to or greater than the vacuum pump exhaust flow output (see chart on the next page). The Filter Assemblies are shipped with filter cartridges, and final filter pad. Optional adaptors are available for KF and NW connections.

Filter Selection Chart (for hazardous/corrosive applications)

Max. Pump Flow Rate (CFM)	Recommended Filter Model Number
3 (5 m <sup>3</sup> /h)	CV-0112-371H
9 (15 m <sup>3</sup> /h)	CV-0118-371H

# Vacuum Pump Inlet & Exhaust Filters

## Exhaust Filters for Hazardous/Corrosive Applications

### Principal Specifications

Model	CV-0112-371H	CV-0118-371H
Port Size	1/2" NPT	3/4" NPT
Max. Flow Rate	3 CFM	9 CFM
Materials of Construction		
Head	---	---
Bowl	304 SS	304 SS
Internals	304 SS	304 SS
Seals	None	None
Maximum Temperature	250°F (121°C)	250°F (121°C)
Maximum Pressure	15 psig (1.0 barg)	15 psig (1.0 barg)
Shipping Weight	0.5 lbs. (0.2 kg)	0.8 lbs. (0.4 kg)
Dimensions	2.9" Dia. X 4.2"H (7cm X 11cm)	4.0" Dia. X 5.3"H (10cm X 13cm)

### Ordering Information

For assistance, call toll-free at 1-800-343-4048 8AM to 5PM Eastern Time

Model	CV-0112-371H (1)	CV-0118-371H (1)
Number of Filter Cartridges Required	---	---
Replacement Filter Cartridges		
Box of 3	---	---
Box of 7	---	---
Box of 10	---	---
Number of Pressure Relief Retainers #20222	---	---
Optional Accessories:	#11015 Back Pressure Gage, Stainless Steel, 0-15 psi (0-1.0 barg) rating, 1/4" NPT fitting. Vacuum Pump-to-Filter Adaptors: Please refer to Pages 141 - 142.	

#### Notes:

1 Filter cartridge is permanently sealed into housing. The entire unit is disposable. Pressure relief filter tube retainer not available in these models.

# Vacuum Pump Inlet & Exhaust Filters

## Exhaust Filters for Non-Hazardous/Non-Corrosive Applications

Eliminate 99.9% oil mist and smoke from vacuum pump exhaust

Prevent oil accumulation in ductwork

Recover expensive lubricating oils, and automatically return filtered oil to pump

Eliminate potential OSHA and EPA violations

### Balston Vacuum Pump Exhaust Filters

Balston Vacuum Pump Exhaust Filters remove all visible oil mist and smoke from vacuum pump exhaust, even when it is saturated with oil. The high efficiency filter cartridge continuously drains the collected liquid, allowing the user to recover expensive lubricating fluid. Filters are available for pumps with flow ratings ranging from 3 to 850 cfm (5-1440 m<sup>3</sup>/h).

### How To Select The Filter

For most applications, simply select the filter assembly which has a flow capacity equal to or greater than the vacuum pump exhaust flow output (see chart below). The filter assemblies are shipped with filter cartridges, pressure gage (20 cfm and larger), and final filter pad. Optional adaptors are available for KF and NW connections.

#### Filter Selection Chart

(for non-hazardous/non-corrosive applications)

Max. Pump Flow Rate (CFM/m <sup>3</sup> /h)	Recommended Filter Model Number
3 (5)	9955-12-371H, 9956-12-371H
9 (15)	AR-009-371H
15 (25)	AR-015-371H
20 (34)	AR-0316-371H
43 (73)	AR-0335-371H
100 (170)	AR-0735-371H
200 (340)	AR-0780-371H
300 (510)	AR-1280-371H
450 (765)	AR-1680-371H
850 (1440)	AR-3080-371H



Model 9955-12



Model AR-009



Model AR-0316



Model AR-0780



Model AR-3080

# Vacuum Pump Inlet & Exhaust Filters

## Exhaust Filters for Non-Hazardous/Non-Corrosive Applications

### Principal Specifications

Model	Port Size	Max. Flow Rate	Materials of Construction				Max. Temp.	Max. Press.	Shipping Wt.	Dimensions
			Head	Bowl	Internals	Seals				
9955-12-371H	1/2"NPT	3CFM	---	Nylon	Nylon	None	250°F(121°C)	15PSIG(1.0barg)	.25lbs(0.1kg)	2"Dia.X3.7"H
9956-12-371H	KF-16	3CFM	---	Nylon	Nylon	None	250°F(121°C)	15PSIG(1.0barg)	.25lbs(0.1kg)	2"Dia.X3.7"H
AR-009-371H	3/4"NPT	9CFM	Aluminum	Aluminum	Alum./SS/Nylon	Viton	300°F(149°C)	15PSIG(1.0barg)	1.0lbs(0.45kg)	3.95"Dia.X5.13"H
AR-015-371H	3/4"NPT	15CFM	Aluminum	Aluminum	Alum./SS/Nylon	Viton	300°F(149°C)	15PSIG(1.0barg)	1.25lbs(0.57kg)	3.95"Dia.X8.13"H
AR-0316-371H	1"NPT	20CFM	Steel	Steel	Anod.Alum.	Buna/Neo	300°F(149°C)	15PSIG(1.0barg)	8lbs(4kg)	7.4"Dia.X8.8"H
AR-0335-371H	1 1/2"NPT	43CFM	Steel	Steel	Anod.Alum.	Buna/Neo	300°F(149°C)	15PSIG(1.0barg)	11lbs(5kg)	7.4"Dia.X15"H
AR-0735-371H	3"NPT	100CFM	Steel	Steel	Anod.Alum.	Buna/Neo	300°F(149°C)	15PSIG(1.0barg)	17lbs(8kg)	10"Dia.X18"H
AR-0780-371H	3"NPT	200CFM	Steel	Steel	Anod.Alum.	Buna/Neo	300°F(149°C)	15PSIG(1.0barg)	23lbs(10kg)	10"Dia.X28"H
AR-1280-371H	4"Flg.(1)	300CFM	Steel	Steel	Anod.Alum.	Buna/Neo	300°F(149°C)	15PSIG(1.0barg)	90lbs(41kg)	19"Dia.X43"H(5)
AR-1680-371H	4"Flg.(1)	450CFM	Steel	Steel	Anod.Alum.	Buna/Neo	300°F(149°C)	15PSIG(1.0barg)	100lbs(45kg)	19"Dia.X43"H(5)
AR-3080-371H	6"Flg.(1)	850CFM	Steel	Steel	Anod.Alum.	Buna/Neo	300°F(149°C)	15PSIG(1.0barg)	150lbs(68kg)	23"Dia.X43"H(5)

### Ordering Information

For assistance, call toll-free at 1-800-343-4048 8AM to 5PM Eastern Time

Model	No. of Filter Cartridges Required	Replacement Filter Cartridges			Cover (2) (Optional)	No. Pressure Relief Retainers #20222
		Box of 3	Box of 7	Box of 10		
9955-12-371H (3)	1	3/9955-12-371H	---	9955-12-371H	---	(4)
9956-12-371H (3)	1	3/9956-12-371H	---	9956-12-371H	---	(4)
AR-009-371H	1	2/BE200-168-371H (6)	---	BE200-168-371H	---	(4)
AR-015-371H	1	2/BE200-248-371H (6)	---	BE200-248-371H	---	(4)
AR-0316-371H	3	3/200-16-371H	---	---	19158	1
AR-0335-371H	3	3/200-35-371H	---	---	19158	1
AR-0735-371H	7	---	7/200-35-371H	---	19206	2
AR-0780-371H	7	---	7/200-80-371H	---	19206	2
AR-1280-371H	12	---	---	200-80-371H	Included	4
AR-1680-371H	16	---	---	200-80-371H	Included	4
AR-3080-371H	30	---	---	200-80-371H	Included	6

Optional Accessories:

- #20222 Pressure Relief Filter Cartridge Retainer, 4-7 psig (0.3-0.5 barg).
- #20217 Pressure Relief Valve, 3-7 psig (0.2-0.5 barg), 1/4" NPT male fitting.
- #11010 Pressure Gage, 0-15 psig (0-1.0 barg), 1/4" male fitting (incl. on Type AR Filter Assemblies)
- Vacuum pump-to-filter adaptors: refer to pages 141-142.
- #19291 Stand for AR-1680-371H, #19290 Stand for AR-3080-371H.
- #19202 Weather Cap for AR-0735-371H, AR-0780-371H.
- #A05-0097 Seal Set for AR-009-371H, AR-015-371H.

Notes:

- 1 ANSI 150 lb. hole pattern.
- 2 Cover does not provide leak tight seal.
- 3 Filter cartridge is permanently sealed into housing. The entire unit is disposable.
- 4 Pressure relief filter tube retainer not available in these models.
- 5 Height dimension represents filter housing alone. When assembled with a stand, the height is adjustable from 46" to 56" (117cm to 142 cm).
- 6 This model comes in box of 2, not box of 3.

# Vacuum Pump Inlet & Exhaust Filters

## Inlet Filters for Vacuum Service to $10^{-6}$ Torr

Protect vacuum pumps from damage by solids and liquids

Prevent loss of valuable or hazardous materials

Prevent oil backstreaming



CF-0118-30

Vacuum  
Pump Filters

### Model CF-0112 and CF-0118 for Vacuum Service to $10^{-6}$ Torr

Stainless steel housings with welded KF flange inlet and outlet ports and no drain ports. They are designed to be used primarily with the Grade 102 adsorbent cartridges for prevention of oil backstreaming (see cartridge selection chart to the right). They may also be used with Grade 30 cartridges for removal of high concentrations of solids, but the absence of drain ports precludes the use of CF housings for liquid removal in vacuum applications.

### Filter Selection Chart

<b>Grade 30 Cartridges</b>	<b>For removal of relatively high concentrations of solids</b>
Efficiency:	90% at 0.1 micron
Loss in pumping speed:	9% at maximum flow rate
Materials of construction:	Polypropylene cartridge, EPR seals
Maximum temperature:	180°F (82°C)
<b>Grade 102 Cartridges</b>	<b>For prevention of oil backstreaming and filtration of relatively low concentrations of solids</b>
Efficiency for preventing oil backstreaming:	99.99%
Life: vacuum	Approximately 1000 hours at 10 microns
Efficiency for solids filtration:	99.99% at 0.1 micron
Materials of construction:	Molecular Sieve Type 4A adsorbent, EPR seals
Maximum temperature:	100°F (38°C)

# Vacuum Pump Inlet & Exhaust Filters

## Inlet Filters for Vacuum Service to 10<sup>-6</sup> Torr

### Principal Specifications

Model	CF-0112	CF-0118
Recommended Vacuum Service	10 <sup>-6</sup> Torr	10 <sup>-6</sup> Torr
Max. Flow Rating of Vacuum Pump	3 CFM (5 m <sup>3</sup> /hr)	9 CFM (15 m <sup>3</sup> /hr)
Inlet and Outlet Ports	KF-25	KF-25
Materials of Construction		
Head	304 SS	304 SS
Bowl	304 SS	304 SS
Internals	304 SS	304 SS
Seals	None	None
Maximum Temperature	180°F (82°C) (1)	180°F (82°C) (1)
Shipping Weight	0.5 lbs. (0.2 kg)	0.8 lbs. (0.4 kg)
Dimensions	2.9"W X 4.4"L (7cm X 11cm)	3.9"W X 5.9"L (10cm X 15cm)

Notes:

1 Maximum temperature grade 102 Cartridge is 100°F (38°F).

2 Filter Cartridge is permanently sealed into housing. The entire unit is disposable.

Vacuum  
Pump Filters

### Ordering Information

For assistance, call toll-free at 1-800-343-4048 8AM to 5PM Eastern Time

Assembly with Grade 30 Particulate Filter	Assembly with Grade 102 Backstreaming Filter	Number of Filter Cartridges Required (2)
CF-0112-30	CF-0112-102	N/A
CF-0118-30	CF-0118-102	N/A

# Vacuum Pump Inlet & Exhaust Filters

## Inlet Filters for Vacuum Service to 2 Torr

Protect vacuum pumps from damage by solids and liquids

Prevent loss of valuable or hazardous materials

Prevent oil backstreaming



R-009-30

R-015-30

Vacuum  
Pump Filters

**Models CV-0112-30 and CV-0118-30 for hazardous/corrosive applications and low flow applications**

Stainless steel housings with NPT inlet, outlet and drain ports. Used only with Grade 30 filter cartridges.

**Models R-009-30 and R-015-30 for non-hazardous/non-corrosive applications and higher flow applications**

Steel housing with NPT inlet, outlet and drain ports. Used only with Grade 30 filter cartridges.

### Filter Selection Chart

Grade 30 Cartridges	For removal of relatively high concentrations of solids and liquids
Efficiency:	90% at 0.1 micron
Loss in pumping speed:	9% at maximum flow rate
Materials of construction:	Polypropylene cartridge, EPR seals
Maximum temperature:	180°F (82°C)



# Vacuum Pump Inlet & Exhaust Filters

## Inlet Filters for Vacuum Service to 2 Torr

### Principal Specifications

Model	CV-0112-30	CV-0118-30	R-009-30	R-015-30
Recommended Vacuum Service	2 Torr	2 Torr	2 Torr	2 Torr
Max. Flow Rating of Vacuum Pump	3 CFM	9 CFM	9 CFM	15 CFM(1)
Inlet and Outlet Ports	1/2" NPT	3/4" NPT	3/4" NPT	3/4" NPT
Drain Port	1/8" NPT (2)	1/8" NPT (2)	1/8" NPT (2)	1/8" NPT (2)
Materials of Construction				
Head	304 SS	304 SS	Aluminum	Aluminum
Bowl	304 SS	304 SS	Aluminum	Aluminum
Internals	304 SS	304 SS	Aluminum/SS/Nylon	Aluminum/SS/Nylon
Seals	None	None	Viton	Viton
Maximum Temperature	180°F (82°C)	180°F (82°C)	180°F (82°C)	180°F (82°C)
Shipping Weight	0.5 lbs. (0.2 kg)	0.8 lbs. (0.4 kg)	1.0 lbs. (0.45 kg)	1.25 lbs. (0.57 kg)
Dimensions	2.9"W X 4.4"L (7cm X 11cm)	3.9"W X 5.9"L (10cm X 15cm)	3.95"W X 5.13"L (10cm X 13cm)	3.95"W X 8.13"L (10cm X 21cm)

### Ordering Information

For assistance, call toll-free at 1-800-343-4048 8AM to 5PM Eastern Time

Assembly with Grade 30 Particulate Filter	Number of Filter Cartridges Required	Box of 2	Box of 10
CV-0112-30	(3)	---	
CV-0118-30	(3)	---	
R-009-30	1	2/BE100-163-30	BE100-163-30
R-015-30	1	2/BE100-235-30	BE100-235-30

#### Notes:

1 For higher flow capacity inlet filters, please consult factory.

2 Drain port must be downward for liquid removal.

3 Filter cartridge is permanently sealed into housing. The entire unit is disposable.

Vacuum Pump Filters

# Vacuum Pump Inlet & Exhaust Filters

## Recommended Exhaust Filters for Vacuum Pumps

Vacuum  
Pump Filters

Pump Model No.	Pump Rating CFM (m <sup>3</sup> /hr) (Free Air)	Pump Exhaust (NPT Female Unless Otherwise Noted)	Recommended Balston Filter Non-Hazardous Non-Corrosive Applications	Balston Anodized Aluminum Pump-To-Filter Adaptor (1)	Recommended Balston Filter Hazardous and Corrosive Applications	Balston Stainless Steel Pump-To-Filter Adaptor (1)
<b>Alcatel Pumps</b>						
ZM/ZT 1004A/AC	3.2 (5.4)	NW 25	AR-009	14175	CV-0112	14182
ZM/ZT 1012A	11 (19)	NW 25	AR-015	14173		
ZM/ZT 1030	17 (29)	1" OD Tube	AR-0316			
ZM/ZT 1033	27 (46)	NW 40	AR-0335	14174		
ZT 1060	30 (51)	1.63" OD Tube	AR-0335			
ZT 1063	50 (85)	NW 40	AR-0735	14174 (2)		
ZT 1200A	150 (255)	1.63" OD Tube	AR-0780			
ZM/ZT 2004A	3.2 (5.4)	NW 25	AR-009	14173	CV-0112	14182
ZM/ZT 2007	7 (12)	NW 25	AR-009	14173	CV-0118	14182
ZM/ZT 2008A/AC	7 (12)	NW 25	AR-009	14173	CV-0118	14182
ZM/ZT 2012A/AC/H	11 (19)	NW 25	AR-015	14173		
UM/UT 2020	15.9 (27)	NW 25	AR-015	14173		
ZM/ZT 2030/H	17 (29)	1" OD Tube	AR-0316			
ZM/ZT 2033/C	27 (46)	NW 40	AR-0335	14174		
ZT 2060/H/HUS	30 (51)	1.63" OD Tube	AR-0335			
ZT 2063/C	50 (85)	NW 40	AR-0735	14174 (2)		
ZT 2100A/AC	90 (153)	NW 50	AR-0735			
2002A	1.4 (2.4)	DN16	9955-12, 9956-12		CV-0112	
2005	3.8 (6.5)	DN25	AR-009		CV-0118	
2015	10.6 (18)	DN25	AR-015			
2021	14.6 (25)	DN25	AR-015			
2010	6.8 (12)	DN25	AR-009		CV-0118	
AMD1	0.82 (1.4)	DN16	9955-12, 9956-12		CV-0112	
AMD4	2.36 (4.0)	DN16	9955-12, 9956-12		CV-0112	
A100L	55.8 (95)	DN25	AR-0735			
<b>Roots Vacuum Pumps</b>						
RSV 151	89 (151)	ISO/DN63	AR-0735			
RSV 301	177 (301)	ISO/DN63	AR-0780			
RSV 601	354 (601)	ISO/DN100	AR-1680			
RSV 1002	594 (1009)	ISO/DN100				
LRS1						
RSV 151B+RVP2033D	106 (180)	DN40	AR-0780			
RSV 301B+2033D	212 (360)	DN40	AR-1280			
RSV 301B+RVP 2063D	212 (360)	DN40	AR-1280			
LRS2						
RSV 151+RVP 2021	106 (180)	DN25	AR-0780			
RSV 601+RVP 2033	424 (720)	DN40	AR-1680			
MRS1						
RSV 301B+AMV 200/300	212 (360)	DN50	AR-1280			
RSV 601B+AMV 200/300	212 (360)	DN40	AR-1280			
RSV 1002AMV200/300	424 (720)	DN40	AR-1680			

Notes:

1 If no part number is listed, adaptor is not supplied by Parker. In most cases, customer can assemble adaptor from standard pipe fittings. Refer to pages 141-142.

2 Requires 3" Male x 1 1/2" Female reducing bushing supplied by customer.

# Vacuum Pump Inlet & Exhaust Filters

## Recommended Exhaust Filters for Vacuum Pumps

Pump Model No.	Pump Rating CFM (m <sup>3</sup> /hr) (Free Air)	Pump Exhaust (NPT Female Unless Otherwise Noted)	Recommended Balston Filter Non-Hazardous Non-Corrosive Applications	Balston Anodized Aluminum Pump-To-Filter Adaptor (1)	Recommended Balston Filter Hazardous and Corrosive Applications	Balston Stainless Steel Pump-To-Filter Adaptor (1)
<b>Balzers Pumps</b>						
UNO/DUO 1.5A	1.0 (2)	KF10	9955-12		CV-0112	
UNO/DUO 004A/B	2.7 (5)	KF25	9955-12	14175	CV-0112	14182
UNO/DUO 008A/B	5.2 (9)	KF25	R-009	14173	CV-0118	14182
UNO/DUO 012A	8.2 (14)	KF25	R-009	14173	CV-0118	14182
UNO/DUO 016B	10.6 (18)	KF25	R-015	14173		
UNO/DUO 030A	19.7 (33)	KF40	AR-0316	14174		
UNO/DUO 060A	39.3 (67)	KF40	AR-0335	14174		
UNO/DUO 250A	157 (267)	ISO 100	AR-0780			
UNO 100	56 (95)	32mm OD Tube (4)	AR-0735			
DUO 100	57 (97)	32mm OD Tube (4)	AR-0735			
UNO/DUO 120A	75.3 (128)	ISO 63	AR-0735			
UNO 170	91.2 (155)	32mm OD Tube (4)	AR-0735			
DUO 170	100 (170)	32mm OD Tube (4)	AR-0735			
BA 251	158.9 (270)	ISO 63	AR-0780			
BA 501	320.7 (545)	ISO 100	AR-1680			
UNO 2.5	1.7 (3)	DN16	9955-12, 9956-12		CV-0112	
UNO 6	3.5 (6)	G 3/8	R-009		CV-0118	
UNO 20	12.4 (21)	ISO-KF25	R-015			
UNO 60	36.5 (62)		AR-0735			
UNO 90	55.3 (94)	DN40	AR-0735			
UNO 200	123.6 (210)	DN	AR-1280			
UNO 240	158.9 (270)	DN	AR-1280			
UNO 400	270.7 (460)	DN63 ISO-F	AR-3080			
UNO 630	400.2 (680)	DN63 ISO-F	AR-3080			
DUO 5	3.5 (6)	DN16	R-009		CV-0118	
DUO 10	7 (12)	DN25	R-015		CV-0118	
DUO 20	14.1 (24)	DN25	R-015			
DUO 35	21.2 (36)	DN40	AR-0335			
DUO 65	41.2 (70)	DN100	AR-0735			
DUO 120	84.7 (144)	DN63	AR-0780			
DUO 250	176.6 (300)	DN100	AR-1280			
<b>Beach-Russ Pumps</b>						
SS 1	6 (10)	3/4"	R-009		CV-0118	
SS 1 1/2	9 (15)	3/4"	R-009		CV-0118	
SS 2	15 (25)	3/4"	R-015			
SS 3	28 (48)	1"	AR-0335			
SS 4	45 (76)	1 1/4"	AR-0735			
SS 5	60 (102)	1 1/2"	AR-0735			
RP/RV 6	8.5 (14)	1/2"	R-009		CV-0118	
SS 6	75 (127)	1 1/2"	AR-0735			
SS 7	110 (187)	2"	AR-0780			
SS 8	150 (255)	2 1/2"	AR-0780			
SS 9	225 (382)	4"	AR-1280			
SS 10	375 (637)	6"	AR-1680			
RP/RV 12	18 (31)	3/4"	AR-0316			
RP 15	30 (51)	1 1/2"	AR-0335			
RP 15-6	30 (51)	1"	AR-0335			
RP 30	50 (85)	1 1/2"	AR-0735			
RP 30-6	50 (85)	1"	AR-0735			
RP 50/50-6	80 (136)	2"	AR-0735			

**Notes:**

- 3 Requires 2" Male x 1 1/2" Female reducing bushing supplied by customer.
- 4 Exhaust port is horizontal. Customer should provide elbow so that filter is mounted vertically.
- 5 Requires 1" Male x 1 1/2" Female bushing supplied by customer.
- 6 Multiple filters piped in parallel are required.

# Vacuum Pump Inlet & Exhaust Filters

## Recommended Exhaust Filters for Vacuum Pumps

Vacuum  
Pump Filters

Pump Model No.	Pump Rating CFM (m <sup>3</sup> /hr) (Free Air)	Recommended Pump Exhaust (NPT Female Unless Otherwise Noted)	Recommended Balston Filter Non-Hazardous Non-Corrosive Applications	Balston Anodized Aluminum Pump-To-Filter Adaptor (1)	Balston Filter Hazardous and Corrosive Applications	Balston Stainless Steel Pump-To-Filter Adaptor (1)
<b>Beach-Russ Pumps</b>						
RP 135/135-12	140 (238)	3"	AR-0780			
RP-150/150-12	175 (297)	3"	AR-0780			
RP 250	310 (527)	5"	AR-1280			
RP 250-12	310 (527)	4"	AR-1280			
RP 325	375 (637)	5"	AR-1680			
RP 325-12	375 (637)	4"	AR-1680			
RP 375	500 (850)	6"	AR-3080			
RP 375-50	500 (850)	4"	AR-3080			
RP 750	900 (1529)	8"	AR-1680 (2)			
RP 750-50	900 (1529)	5"	AR-1680 (2)			
RP 1000	1100 (1869)	8"	AR-3080 (2)			
RP 1000-50	1100 (1869)	5"	AR-3080 (2)			
84-A-RVF	250 (425)		AR1280			
98-A-RVF	410 (697)		AR1680			
14	8.5 (14)	4"	R-009		CV-0118	
20	12 (20)	4"	R-015			
25	17 (29)	4"	AR-0316			
42	25 (42)	4"	AR-0335			
60	38 (65)	4"	AR-0335			
82	49 (83)	4"	AR-0735			
128	75 (127)	4"	AR-0735			
170	103 (175)	4"	AR-0780			
240	141 (240)	4"	AR-0780			
320	189 (321)	4"	AR-0780			
480	285 (484)	4"	AR1280			
642	378 (642)	4"	AR1680			
910	540 (917)	4"	AR-3080			
1210	710 (1206)	4"	AR-3080			
OTL/VP30	50 (85)	1.5"	AR-0735			
OTL/VP50	80 (136)	2"	AR-0735			
OTL/VP135	140 (238)	3"	AR-0780			
OTL/VP150	175 (297)	3"	AR-0780			
OTL/VP250	310 (527)	5"	AR-1680			
OTL/VP325	375 (637)	5"	AR-1680			
3P	48 (82)	1.5"	AR-0735			
4P	73 (124)	1.5"	AR-0735			
5P	100 (170)	2.5"	AR-0780			
6P	125 (212)	2.5"	AR-0780			
7P	175 (297)	3"	AR-0780			
8P	225 (382)	3"	AR-1280			
9P	300 (510)	4"	AR-1280			
0	1 (2)	1/4"	9955-12, 9956-12		CV-0112	
1	2 (3)	1/4"	9955-12, 9956-12		CV-0112	

**Notes:**

1 If no part number is listed, adaptor is not supplied by Parker. In most cases, customer can assemble adaptor from standard pipe fittings. Refer to pages 141-142.  
2 Multiple filters piped in parallel are required.

# Vacuum Pump Inlet & Exhaust Filters

## Recommended Exhaust Filters for Vacuum Pumps

Pump Model No.	Pump Rating CFM (m <sup>3</sup> /hr) (Free Air)	Pump Exhaust (NPT Female Unless Otherwise Noted)	Recommended Balston Filter Non-Hazardous Non-Corrosive Applications	Balston Anodized Aluminum Pump-To-Filter Adaptor (1)	Recommended Balston Filter Hazardous and Corrosive Applications	Balston Stainless Steel Pump-To-Filter Adaptor (1)
<b>Busch Pumps</b>						
002-192	1.4 (2.4)	KF-16	9956-12		CV-0112	14181
004-192	2.8 (4.8)	KF-16	9956-12		CV-0112	14181
008-192	5.6 (10)	KF-16	R-009	14172	CV-0118	14181 (4)
010-112/118	6 (10)	3/4"	R-009		CV-0118	
016-192	11.2 (19)	KF-16	R-015			
016-112/118	8 (14)	3/4" (3)	R-009		CV-0118	
021-336/338	15 (25)	3/4" (3)	R-015			
025-132/138	20 (34)	1 1/4" (3)	AR-0316			
040-132/138	28 (48)	1 1/4" (3)	AR-0335			
063-132/138	41 (70)	1 1/4" (3)	AR-0335			
110-132/138	63 (107)	1 1/4" (3)	AR-0735			
160-112/118/132/138	117 (199)	2" (3)	AR-0780			
216-002	125 (212)	2"	AR-0780			
225-002	200 (340)	2"	AR-0780			
240-002	300 (510)	2"	AR-1280			
250-112/118/132/138	174 (296)	2" (3)	AR-0780			
263-002	500 (850)	2"	AR-3080			
400-212/218	300 (510)	2"	AR-1280			
630-212/218	430 (731)	3" (3)	AR-1680			
1000-212/228	650 (1104)	6" (3)	AR-3080			
1600-212/228	1100 (1869)	6" (3)	AR-3080 (2)			
429	125 (212)	2"	AR-0780			
433	200 (340)	2"	AR-0780			
437	310 (527)	2"	AR-1280			
441	580 (985)	2"	AR-3080			
445	780 (1325)	6" (3)	AR-3080			
0004	3.3 (506)	3/8"	R-009		CV-0118	
0006	4.2 (701)	3/8"	R-009		CV-0118	
0012	7.1 (12)	3/4"	R-009		CV-0118	
0016	11.2 (19)	3/4"	R-015			
0100	63 (107)	3/4"	AR-0735			
0165	117 (199)	2"	AR-0780			
0205	141 (240)	2"	AR-0780			
0255	180 (306)	2"	AR-0780			
0305	212 (360)	2"	AR-1280			
0400	330 (561)	3"	AR-1680			
0502	413 (702)	3"	AR-1680			
0630	490 (833)	3x	AR-3080			
1000	704 (1196)	6"(ASA)	AR-3080			
1600	1130 (1920)	6"(ASA)	AR-3080(2)			
HO 0429	113 (192)	2"	AR-0780			
HO 0433	176 (299)	2"	AR-0780			
HO 0437	282 (479)	3"	AR-1280			
HO 0441	444 (754)	3"	AR-1680			
LC 0030	20.6 (35)	G1	AR-0335			
LC0060	38.3 (65)	G1	AR-0335			
LC0080	54.1 (92)	DIN40	AR-0735			
LC0110	74.7 (127)	DIN40	AR-0735			
LC0150	100 (170)	DIN40	AR-0735			
LC0220	153 (260)	DIN50	AR-0780			
LC0280	200 (340)	DIN65	AR-0780			
LC0400	271 (460)	DIN65	AR-1280			

Notes:

- 1 If no part number is listed, adaptor is not supplied by Parker. In most cases, customer can assemble adaptor from standard pipe fittings. Refer to pages 141-142.
- 2 Multiple filters piped in parallel are required.
- 3 Requires flange to NPT adaptor from pump manufacturer.
- 4 Requires 3/4" Male x 1/2" Female reducing bushing supplied by customer.

# Vacuum Pump Inlet & Exhaust Filters

## Recommended Exhaust Filters for Vacuum Pumps

Vacuum Pump Filters

Pump Model No.	Pump Rating CFM (m <sup>3</sup> /hr) (Free Air)	Pump Exhaust (NPT Female Unless Otherwise Noted)	Recommended Balston Filter Non-Hazardous Non-Corrosive Applications	Balston Anodized Aluminum Pump-To-Filter Adaptor (1)	Recommended Balston Filter Hazardous and Corrosive Applications	Balston Stainless Steel Pump-To-Filter Adaptor (1)
<b>Central Scientific Pumps (Cenco, Boekel, HYVAC)</b>						
HYVAC 1 (91105)	0.35 (0.59)	3/8"	9955-12		CV-0112	
HYVAC 2 (91305/8)	0.88 (1.5)	1/2"	9955-12		CV-0112	
HYVAC 4 (91482)	1.70 (2.9)	1/2"	9955-12		CV-0112	
HYVAC 7 (91506, 91502)	2.79 (4.7)	1/2"	9955-12		CV-0112	
HYVAC 7S (91138)	2.79 (4.7)	1/2"	9955-12		CV-0112	
HYVAC 14 (91705)	5.6 (10)	3/4"	R-009		CV-0118	
HYVAC 14S (91140)	5.6 (10)	3/4"	R-009		CV-0118	
HYVAC 28 (91905)	10.6 (18)	1 1/2"	R-015			
HYVAC 28S (91142)	10.6 (18)	1 1/2"	R-015			
HYVAC 45 (91955)	17.7 (30)	1 1/2"	AR-0316			
HYVAC 150 (91957)	53 (90)	3"	AR-0735			
HYVAC 300 (91960)	106 (180)	3"	AR-0780			
MEGAVAC (92003)	2.0 (3.4)	1/2"	9955-12		CV-0112	
<b>PRESSOVAC (90510/15/16)</b>	1.23 (2.1)	3.8" OD Tube	9955-12		CV-0112	
<b>DIRECT DRIVE (90703)</b>	1.9 (3.2)	3/8"	9955-12		CV-0112	
<b>DIRECT DRIVE (90700)</b>	1.06 (1.8)	3/8"	9955-12		CV-0112	
2120	4.4 (7.5)	KF25	R-009		CV-0118	
2200	7.3 (12)	KF25	R-009		CV-0118	
HYPERVAC400	13.4 (23)	NW25	R-015			
HYPERVAC600	21 (36)	NW25	AR-0335			
HYPERVAC1000	32 (54)	NW40	AR-0335			
HYPERVAC1500	53 (90)	NW40	AR-0735			
HYVAC30L	1.1 (1.9)		9955-12, 9956-12		CV-0112	
HYVAC50L	2 (3.4)		9955-12, 9956-12		CV-0112	
PRESSOVAC(90510)	1.2 (2.0)	5/8"	9955-12, 9956-12		CV-0112	
MEGAVAC92001	2 (3.4)	1/2"	9955-12, 9956-12		CV-0112	
MEGAVAC1500	50 (85)	PORTS ADAPTABLE	AR-0735			
MEGAVAC2500	88 (150)	PORTS ADAPTABLE	AR-0735			
MEGAVAC4500	150 (255)	PORTS ADAPTABLE	AR-0780			
MEGAVAC7500	250 (425)	PORTS ADAPTABLE	AR-1280			
MEGAVAC15000	300 (510)	PORTS ADAPTABLE	AR-1280			
SUPRVAC012	7.5 (13)	1/2" FNPT	R-009		CV-0118	
SUPRVAC021	15 (25)	1/2" FNPT	R-015			
SUPRVAC025	20 (34)	1"	AR-0335			
SUPRVAC040	30 (51)	1"	AR-0335			
SUPRVAC063	45 (76)	1"	AR-0735			
SUPRVAC100	70 (119)	1"	AR-0735			
SUPRVAC160	110 (187)	2"	AR-0780			
SUPRVAC250	150 (255)	2"	AR-0780			
0505	9.5 (16)	1"	R-015			
1505	19 (32)	1"	AR-0316			
2010	27 (46)	1"	AR-0335			
7530	59 (100)	2"	AR-0735			
10030	84 (143)	2"	AR-0735			

**Notes:**

- 1 If no part number is listed, adaptor is not supplied by Parker. In most cases, customer can assemble adaptor from standard pipe fittings. Refer to pages 141-142.
- 2 Exhaust port is horizontal. Customer should provide elbow so that filter is mounted vertically.
- 3 Multiple filters piped in parallel are required.
- 4 Reducing bushing required. Customer to provide.

# Vacuum Pump Inlet & Exhaust Filters

## Recommended Exhaust Filters for Vacuum Pumps

Pump Model No.	Pump Rating CFM (m <sup>3</sup> /hr) (Free Air)	Pump Exhaust (NPT Female Unless Otherwise Noted)	Recommended Balston Filter Non-Hazardous Non-Corrosive Applications	Balston Anodized Aluminum Pump-To-Filter Adaptor (1)	Recommended Balston Filter Hazardous and Corrosive Applications	Balston Stainless Steel Pump-To-Filter Adaptor (1)
<b>Edwards High Vacuum Pumps</b>						
SPEEDIVAC 2	1.9 (3.2)	3/8 BSPT	9955-12	14157	CV-0112	
E2M1	1.3 (2.2)	3/8 BSPT	9955-12	14157	CV-0112	
E2M2	2 (3.4)	3/4 BSPT	9955-12	14158	CV-0112	
E1/E2M5	4 (6.8)	3/4 BSPT	R-009	14159	CV-0118	
EDM6	5 (8.5)	1/2"	R-009		CV-0118	
E1/E2M8	6.7 (11.4)	3/4 BSPT	R-009	14159	CV-0118	
EDM12	10.3 (17.5)	1/2"	R-015			
E1/E2M18	14.7 (25.0)	3/4"	R-015			
EDM20	14.5 (24.6)	1/2"	R-015			
E2M30	30 (51.0)	KF25	AR-0335	14183		
E1/E2M40	30 (51.0)	KF25	AR-0335	14183		
ED/ES 50	3.5 (5.9)	1/4"	R-009		CV-0118	
ED/ES65	2.3 (3.9)	1/4" (2)	9955-12		CV-0112	
E1/E2M80	57 (96.8)	KF25	AR-0735	14183 (4)		
ED/ES100	3.5 (5.9)	1/4" (2)	R-009		CV-0118	
E1/E2M175	125 (212.4)	1 1/2"	AR-0780			
ED/ES200	6.7 (11.4)	3/8" (2)	R-009		CV-0118	
E1/E2M275	145 (246.4)	1 1/2"	AR-0780			
ES330	11.8 (20.0)	3/8" (2)	R-015			
ISC 450	19.6 (33.3)	1/2"	AR-0316			
ED 500	17.7 (30.1)	1/2"	AR-0316			
ED660	23.3 (39.6)	1/2" (2)	AR-0335			
ISC 900	39.2 (66.6)	3/4"	AR-0335			
ES2000	71 (120.6)	1 1/2"	AR-0735			
ES4000	145 (246.4)	1 1/2"	AR-0780			
ES7500	275 (467.2)	2 1/2"	AR-1280			
RV3	2.7 (4.6)	3/4"	9955-12	(4)	CV-0112	(4)
RV5	4.1 (7.0)	NW25	R-009	14173	CV-0118	14182
RV8	6.9 (11.7)	NW25	R-009	14173	CV-0118	14182
RV12	10.0 (17.0)	NW25	R-015	14173		
<b>Gast Pumps</b>						
0211	1.1 (1.9)	1/4"	9955-12		CV-0112	
0240	1.9 (3.2)	1/4"	9955-12		CV-0112	
0322	2.5 (4.2)	1/4"	9955-12		CV-0112	
0440	4.0 (6.8)	1/4"	R-009		CV-0118	
0465	4.0 (6.8)	3/8"	R-009		CV-0118	
0522	4.0 (6.8)	1/4"	R-009		CV-0118	
0740	5.9 (10.0)	3/8"	R-009		CV-0118	
0765	5.9 (10.0)	3/8"	R-009		CV-0118	
0822	7.2 (12.2)	3/8"	R-009		CV-0118	
1022	10.0 (17.0)	3/8"	R-015			
1065	8.3 (14.1)	1/2"	R-009		CV-0118	
1550	11.5 (19.5)	1/2"	R-015			
2065	17.0 (28.9)	3/4"	AR-0316			
2067	17.0 (28.9)	3/4"	AR-0316			
2565	21.0 (35.7)	3/4"	AR-0335			
3040	31.0 (52.7)	1"	AR-0335			
4565	48.0 (81.6)	3/4"	AR-0735			
5565	55.0 (93.4)	1"	AR-0735			

**Notes:**

- 1 If no part number is listed, adaptor is not supplied by Parker. In most cases, customer can assemble adaptor from standard pipe fittings. Refer to pages 141-142.
- 2 Exhaust port is horizontal. Customer should provide elbow so that filter is mounted vertically.
- 3 Multiple filters piped in parallel are required.
- 4 Reducing bushing required. Customer to provide.

Vacuum Pump Filters

# Vacuum Pump Inlet & Exhaust Filters

## Recommended Exhaust Filters for Vacuum Pumps

Vacuum  
Pump Filters

Pump Model No.	Pump Rating CFM (m <sup>3</sup> /hr) (Free Air)	Pump Exhaust (NPT Female Unless Otherwise Noted)	Recommended Balston Filter Non-Hazardous Non-Corrosive Applications	Balston Anodized Aluminum Pump-To-Filter Adaptor (1)	Recommended Balston Filter Hazardous and Corrosive Applications	Balston Stainless Steel Pump-To-Filter Adaptor (1)
<b>Gast Pumps</b>						
4BA-1-G482X	1.8 (3.1)	1/2"	9955-12		CV-0112	
4AB-1-G482X	1.8 (3.1)	1/2"	9955-12		CV-0112	
4BA-1-G492X	1.8 (3.1)	1/2"	9955-12		CV-0112	
4BA-1-G499	1.8 (3.1)	1/2"	9955-12		CV-0112	
4BA-1-G511X	1.8 (3.1)	1/2"	9955-12		CV-0112	
4BA-1-G538X	1.8 (3.1)	1/2"	9955-12		CV-0112	
5BA-1-G482X	3.5 (3.1)	1/2"	R-009		CV-0118	
5AB-1-G482X	3.5 (5.9)	1/2"	R-009		CV-0118	
5BB-1-G482X	3.5 (5.9)	1/2"	R-009		CV-0118	
6BA-1-G535X	7.0 (12)	1"	R-009			
6AB-1-G504X	7.0 (12)	1"	R-009			
7BA-1-G506X	10.6 (18)	1"	R-015			
7AB-1-G506X	10.6 (18)	1"	R-015			
8BA-1-G506X	14.1 (24)	1 1/4"	R-015			
8AB-G506X	14.1 (24)	1 1/4"	R-015			
1531	1.5 (2.5)	1/8"	9955-12, 9956-12		CV-0112	
0532	0.6 (1.0)	1/8"	9955-12, 9956-12		CV-0112	
1032	1.1 (1.9)	1/4"	9955-12, 9956-12		CV-0112	
1532	1.5 (2.5)	1/4"	9955-12, 9956-12		CV-0112	
2032	2.5 (4.2)	1/4"	9955-12, 9956-12		CV-0112	
3032	2.6 (4.4)	1/4"	9955-12, 9956-12		CV-0112	
0211	1.3 (2.2)	1/4"	9955-12, 9956-12		CV-0112	
2070	20 (34)	1"	AR-0335			
0323-1423	13 (22)	3/4"	AR-0316			
0533	0.6 (1.0)	1/4"	9955-12, 9956-12		CV-0112	
1033	1.1 (1.9)	1/4"	9955-12, 9956-12		CV-0112	
1034	1.6 (2.7)	1/4"	9955-12, 9956-12		CV-0112	
1534	2.2 (3.7)	1/4"	9955-12, 9956-12		CV-0112	
0240-0740	6 (10)	3/8"	R-009		CV-0118	
0456	4 (6.8)	3/8"	R-009		CV-0118	
0765	6 (10)	3/8"	R-009		CV-0118	
1550	14.5 (25)	1/2"	R-015			
1065-2565	8.5-21 (14-36)	3/4"	AR-0335			
2067-2567	17-21 (29-36)	3/4"	AR-0335			
3040	40 (68)	3/4"	AR-0335			
4565	47.5 (81)	1"	AR-0735			
5565	55 (93)	1"	AR-0735			
6066	55 (93)	1"	AR-0735			
1290	112 (190)	1"	AR-0780			
<b>Hitachi Pumps</b>						
SVF 10F	3.6 (6.1)	M24 x 1	R-009	14168	CV-0118	
SVR 16F	5.7 (10)	M24 x 1	R-009	14168	CV-0118	
100 VPS	3.6 (6.1)	M24 x 1	R-009	14168	CV-0118	
160 VPD/VPS	5.7 (10)	M24 x 1	R-009	14168	CV-0118	
16 VP	5.7 (10)	M24 x 1	R-009	14168	CV-0118	
3 VPC	1.8 (3.1)	M14 x 1	9955-12		CV-0112	
4 VPC	3.5 (5.9)	M14 x 1	R-009		CV-0118	

Notes:

1 If no part number is listed, adaptor is not supplied by Parker. In most cases, customer can assemble adaptor from standard pipe fittings. Refer to pages 141-142.

2 Multiple filters piped in parallel are required.



# Vacuum Pump Inlet & Exhaust Filters

## Recommended Exhaust Filters for Vacuum Pumps

Pump Model No.	Pump Rating CFM (m <sup>3</sup> /hr) (Free Air)	Pump Exhaust (NPT Female Unless Otherwise Noted)	Recommended Balston Filter Non-Hazardous Non-Corrosive Applications	Balston Anodized Aluminum Pump-To-Filter Adaptor (1)	Recommended Balston Filter Hazardous and Corrosive Applications	Balston Stainless Steel Pump-To-Filter Adaptor (1)
<b>Ingersoll-Rand Pumps</b>						
AV/AVX2	2.7 (4.6)	3/8"	9955-12		CV-0112	
BV/BVX2	5.4 (9.2)	3/8"	R-009		CV-0118	
V23A/V23AX7	9 (15)	3/4"	R-009		CV-0118	
V235/V235X1	18 (31)	1"	AR-0316			
V244/V244X2	32 (54)	1 1/4"	AR-0335			
V255/V255X3	60 (102)	1 1/2"	AR-0735			
V255X5	60 (102)	1 1/2"	AR-0735			
7V/7VX5	99 (168)	1 1/2"	AR-0735			
15V/15VX7	133 (226)	2"	AR-0780			
20VX10	214 (364)	2 1/2"	AR-1280			
20V/20VX15	294 (500)	2 1/2"	AR-1280			
15VD7.5	132 (224)	2"	AR-0780			
20VX15	214 (364)	2.5"	AR-1280			
2V235D1.5	36 (61)		AR-0335			
2-V244D2	36 (61)		AR-0335			
2-V255031D5	120 (204)		AR-0780			
2-7E7.5	198 (336)		AR-0780			
2-15VE7.5	264 (449)		AR-1280			
2-20VA15	428 (727)		AR-1680			
2-20VA20	588 (999)		AR-3080			
255	60 (102)	1.5"	AR-0735			
<b>ITT Pneumotive (Leiman Brothers)</b>						
B	10 (17)	3/4"	R-015			
C	18 (31)	1"	AR-0316			
29-3J	20 (34)	1"	AR-0316			
195-2	20 (34)	3/4"	AR-0316			
C-3	22 (37)	1"	AR-0335			
30-3	35 (59)	1"	AR-0335			
C-6	37 (63)	1 1/2"	AR-0335			
29-6J	50 (85)	1 1/2"	AR-0735			
30-6	60 (102)	1 1/2"	AR-0735			
100	112 (190)	1 1/2"	AR-0780			
100J	125 (212)	1 1/2"	AR-0780			
107/107J	200 (340)	3'	AR-0780			

**Notes:**

1 If no part number is listed, adaptor is not supplied by Parker. In most cases, customer can assemble adaptor from standard pipe fittings. Refer to pages 141-142.

2 Multiple filters piped in parallel are required.

# Vacuum Pump Inlet & Exhaust Filters

## Recommended Exhaust Filters for Vacuum Pumps

Vacuum  
Pump Filters

Pump Model No.	Pump Rating CFM (m <sup>3</sup> /hr) (Free Air)	Pump Exhaust (NPT Female Unless Otherwise Noted)	Recommended Balston Filter Non-Hazardous Non-Corrosive Applications	Balston Anodized Aluminum Pump-To-Filter Adaptor (1)	Recommended Balston Filter Hazardous and Corrosive Applications	Balston Stainless Steel Pump-To-Filter Adaptor (1)
<b>Kinney Pumps</b>						
KC/KVS/KVC-2	2 (3.4)	3/4"	9955-12		CV-0112	
KC/KVC-3	3 (5.1)	3/4"	9955-12		CV-0112	
KC-5	5 (8.5)	3/4"	R-009		CV-0118	
KVC-6	5.8 (9.9)	3/4"	R-009		CV-0118	
KC-8	8 (13.6)	3/4"	R-009			
KS-13	13 (22.1)	1 1/4"	R-015			
TCS-14	14 (23.8)	3/4"	R-015			
KC-15	15 (25.5)	1 1/4"	R-015			
KS-15	15 (25.5)	1 1/4"	R-015			
KTC-21	21 (35.7)	1"	AR-0335			
TCS-21	21 (35.7)	3/4"	AR-0335			
KD-30	33 (56.1)	1 1/4"	AR-0335			
TCS-35	30 (51.0)	1 1/4"	AR-0335	14174		
KD-50	52 (88.3)	1 1/4"	AR-0735			
TCS-55	54 (91.7)	1 1/2"	AR-0735			
KTC-60	60 (101.9)	1 1/2" (2)	AR-0735			
KDH-65	69 (117.2)	1 1/2"	AR-0735			
TCS-70	71 (120.6)	1 1/2"	AR-0735			
KDH-80	83 (141.0)	1 1/2"	AR-0735			
TCS-90	88 (149.5)	2"	AR-0735			
KTC-112	107 (181.8)	2" (2)	AR-0780			
KDH-130	134 (227.7)	2"	AR-0780			
KDH-150	165 (280.3)	2"	AR-0780			
KT-150	144 (244.7)	2" (2)	AR-0780			
KTC-225	221 (375.5)	3" (2)	AR-1280			
KT-300	296 (502.9)	3" (2)	AR-1280			
KT-500	494 (839.3)	3" (2)	AR-3080			
KT-850	778 (1321.8)	4" Flange	AR-3080			
KT-170LP	100 (169.9)	2"	AR-0735			
KT-275LP	162 (275.2)	2"	AR-0780			
KT-505LP	300 (509.7)	3"	AR1680			
KT-840FP	490 (832.5)	4"	AR-3080			
KT-135VFP	780 (1325.2)	5"	AR-3080			
<b>Lammert Pumps</b>						
10301	2 (3.4)	1/2"	9955-12		CV-0112	
10302	2 (3.4)	1/2"	9955-12		CV-0112	
10305/01131	5 (8.5)	3/4"	R-009		CV-0118	
10307/01133	7.5 (12.7)	1"	R-009		CV-0118	
10310/02131	10 (17.0)	1"	R-015			
02133	15 (25.5)	3/4"	R-015			
03131/03231	20 (34.0)	1 1/4"	AR-0316			
04231/04131	30 (51.0)	1 1/4"	AR-0335			
03133/03233	30 (51.0)	1 1/4"	AR-0335			
04133/04233	50 (85.0)	1 1/4"	AR-0735			
05131/05231	75 (127.4)	2"	AR-0735			
06231/05133/05233	100 (169.9)	2"	AR-0735			
07231	125 (212.4)	3"	AR-0780			
06233/08231	150 (254.9)	3"	AR-0780			
07233	200 (339.8)	3"	AR-0780			
08233/09231	250 (424.8)	3"	AR-1280			
09233	350 (594.7)	3"	AR-1680			

**Notes:**

1 If no part number is listed, adaptor is not supplied by Parker. In most cases, customer can assemble adaptor from standard pipe fittings. Refer to pages 141-142.

2 Exhaust port is horizontal. Customer should provide elbow so that filter is mounted vertically.

3 Multiple filters piped in parallel are required.

# Vacuum Pump Inlet & Exhaust Filters

## Recommended Exhaust Filters for Vacuum Pumps

Pump Model No.	Pump Rating CFM (m <sup>3</sup> /hr) (Free Air)	Pump Exhaust (NPT Female Unless Otherwise Noted)	Recommended Balston Filter Non-Hazardous Non-Corrosive Applications	Balston Anodized Aluminum Pump-To-Filter Adaptor (1)	Recommended Balston Filter Hazardous and Corrosive Applications	Balston Stainless Steel Pump-To-Filter Adaptor (1)
<b>Leybold Heraeus Pumps</b>						
D/S 2A	2.2 (3.7)	KF 16	9956-12		CV-0112	14181
D/S 4A	4.5 (7.6)	KF 16	R-009	14172	CV-0118	14181 (3)
D/S 8A	7.0 (12)	KF 25	R-009	14173	CV-0118	14182
D 4B	3.4 (5.8)	KF 16	R-009	14172	CV-0118	14181 (3)
D 8B	6.9 (12)	KF 16	R-009	14172	CV-0118	14181 (3)
D/S 16A	14.1 (24)	KF 25	R-015	14173		
D25	20 (34)	KF 25	AR-0316	14173		
D/S 30A	26.8 (46)	KF 40	AR-0335	14178		
SV 40	30 (51)	1 1/4"	AR-0335			
DK 50	32 (54)	KF 50	AR-0335			
D/S 60A	36.7 (62)	KF 40	AR-0335	14178		
D 65	53 (90)	KF 40	AR-0735	14174 (4)		
SV 65	45 (76)	1 1/4"	AR-0335			
E 75	49 (83)	KF 50	AR-0735			
D/S 90A	55 (93)	KF 40	AR-0735	14174 (4)		
DK 100	65 (110)	KF 50	AR-0735			
SV 100	70 (119)	2"	AR-0735			
E 150	94 (160)	KF 50	AR-0735			
SV 180	125 (212)	2"	AR-0780			
DK 200	130 (221)	3" ASA Flange	AR-0780			
E 250	162 (275)	3" ASA Flange	AR-0780			
SV 280	200 (340)	2"	AR-0780			
SV 500	318 (540)	3"	AR-1280			
SV 580	339 (574)	3"	AR-1680			
D25BCS	20 (34)		AR-0316			
D40BCS	32.5 (55)		AR-0335			
D65BCS	53 (90)		AR-0735			
D25B	20.9 (36)		AR-0335			
SV16B	11.2 (19)		AR-0316			
SV25B	18.3 (31)	1/2" NPT	AR-0136			
SV65B	41.8 (71)		AR-0335			
SV100B	68.9 (117)		AR-0735			
SV200	129.5 (220)		AR-0780			
SV300	200 (340)	2" BSP	AR-0780			
SV500	336 (571)		AR-1680			
SV630	494.8 (841)		AR-3080			
SV1200	677 (1150)		AR-3080			
SP250	177 (301)		AR-0780			
SP630	371 (630)		AR-1680			
SV40B	31.2 (53)		AR-0335			
D10E	9.3 (16)		R-015			

**Notes:**

- 1 If no part number is listed, adaptor is not supplied by Parker. In most cases, customer can assemble adaptor from standard pipe fittings. Refer to pages 141-142.
- 2 Requires 2" Male x 1 1/2" Female reducing bushing supplied by customer.
- 3 Requires 3/4" Male x 1/2" Female reducing bushing supplied by customer.
- 4 Requires 3" Male x 1 1/2" Female reducing bushing supplied by customer.
- 5 Requires Multiple Filters piped in parallel.

Vacuum Pump Filters

# Vacuum Pump Inlet & Exhaust Filters

## Recommended Exhaust Filters for Vacuum Pumps

Vacuum  
Pump Filters

Pump Model No.	Pump Rating CFM (m <sup>3</sup> /hr) (Free Air)	Pump Exhaust (NPT Female Unless Otherwise Noted)	Recommended Balston Filter Non-Hazardous Non-Corrosive Applications	Balston Anodized Aluminum Pump-To-Filter Adaptor (1)	Recommended Balston Filter Hazardous and Corrosive Applications	Balston Stainless Steel Pump-To-Filter Adaptor (1)
<b>Marvac Pumps</b>						
A-1	1.06 (1.8)	3/8"	9955-12		CV-0112	
A-2	1.06 (1.8)	3/8"	9955-12		CV-0112	
A-10	1.6 (2.7)	3/8"	9955-12		CV-0112	
A-20	1.6 (2.7)	3/8"	9955-12		CV-0112	
A-222	3.5 (5.9)	1/2"	R-009		CV-0118	
B-2	2.65 (4.5)	1/2"	9955-12		CV-0112	
B-3	5.5 (9.3)	3/4"	R-009			
B-6	20 (34.0)	1 1/4"	AR-0316			
B-20	3.53 (6.0)	1/2"	R-009		CV-0118	
B-30	8.8 (15.0)	1"	R-009		CV-0118	
B-222	7 (11.9)	3/4"	R-009		CV-0118	
R-10	1.5 (2.5)	3/8"	9955-12		CV-0112	
R-20	1.5 (2.5)	3/8"	9955-12		CV-0112	
R-22	2.65 (4.5)	3/8"	9955-12		CV-0112	
R-55	5.5 (9.3)	3/8"	R-009		CV-0118	
<b>Maxima Pumps (Fisher Scientific)</b>						
D2A (01-057-2A)	2.2 (3.7)	KF 16	9956-12		CV-0112	14181
D4A (01-057-4A)	4.5 (7.6)	KF 16	R-009	14172	CV-0118	14181 (3)
D8A (01-057-8A)	7.0 (11.9)	KF 25	R-009	14173	CV-0118	14182
D16A (01-057-16A)	14.1 (24.0)	KF 25	AR-0316	14173		
D30A (01-057-30A)	26.8 (45.5)	KF 40	AR-0335	14174		
D60A (01-057-60A)	36.7 (62.4)	KF 40	AR-0335	14174 (4)		
D90A (01-057-90A)	55 (93.4)	KF 40	AR-0735			
M4C	2.6 (4.4)		9955-12, 9956-12		CV-0112	
M6C	3.4 (5.8)		R-009		CV-0118	
M8C	6.1 (10.4)		R-009		CV-0118	
<b>Precision Scientific Pumps</b>						
DD-20	0.7 (1.2)	3/4"	9955-12		CV-0112	
D-25	0.9 (1.5)	3/4"	9955-12		CV-0112	
S/PV-35	1.25 (2.1)	3/4"	9955-12		CV-0112	
DD-50	1.77 (3.0)	3/4"	9955-12		CV-0112	
D-75	2.7 (4.6)	3/4"	9955-12		CV-0112	
DD-90	3.2 (5.4)	3/4"	R-009		CV-0118	
DD-100	3.54 (6.0)	3/4"	R-009		CV-0118	
D-150	5.3 (9.0)	3/4"	R-009		CV-0118	
DD/DDC-195	7 (11.9)	3/4"	R-009		CV-0118	
S/D-300	10.6 (18.0)	1"	R-015			
DD/DDC 310	11 (18.7)	3/4"	R-015			
DD/DDC 475	17 (28.9)	3/4"	AR-0316			
S/D-500	17.6 (29.9)	1 1/4"	AR-0316			
S/D-1000	35.3 (60.0)	1 1/2"	AR-0335			
S/D-1500	53 (90.0)	1 1/2"	AR-0735			

Notes:

- 1 If no part number is listed, adaptor is not supplied by Parker. In most cases, customer can assemble adaptor from standard pipe fittings. Refer to pages 141-142.
- 2 Multiple filters piped in parallel are required.
- 3 Requires 1 1/2" Male x 1" Female reducing bushing supplied by customer.
- 4 Requires 3" Male x 1 1/2" Female reducing bushing supplied by customer.
- 5 Requires 2" Male x 1 1/2" Female reducing bushing supplied by customer.

# Vacuum Pump Inlet & Exhaust Filters

## Recommended Exhaust Filters for Vacuum Pumps

Pump Model No.	Pump Rating CFM (m <sup>3</sup> /hr) (Free Air)	Pump Exhaust (NPT Female Unless Otherwise Noted)	Recommended Balston Filter Non-Hazardous Non-Corrosive Applications	Balston Anodized Aluminum Pump-To-Filter Adaptor (1)	Recommended Balston Filter Hazardous and Corrosive Applications	Balston Stainless Steel Pump-To-Filter Adaptor (1)
<b>Quincy Pumps</b>						
QSVB-10	79 (134)	1 1/4"	AR-0735			
QSVB-20	134 (228)	1 1/4"	AR-0780			
QSVI-20	159 (270)	2 1/2"	AR-0780			
QSVI-40	315 (535)	2 1/2"	AR-1280			
QV-.75	8.5 (14)	.5" NPT	R-009		CV-0118	
QV-1	12 (20)	.5" NPT	R-015			
QV-1.5	25 (42)	.75" NPT	AR-0335			
QV-2	38 (65)	1" NPT	AR-0335			
QV-3	50 (85)	1" NPT	AR-0735			
QV-5	75 (127)	1.5" NPT	AR-0735			
QV-5.5	103 (175)	1.5" NPT	AR-0780			
QV-7.5	141 (240)	2" NPT	AR-0780			
QV-10	189 (621)	2" NPT	AR-0780			
QV-15	245 (416)	3" NPT	AR-1280			
QV-20	378 (642)	3" NPT	AR-1680			
QV-30	540 (917)	4" NPT	AR-3080			
QV-40	716 (1216)	4" NPT	AR-3080			

**Notes:**

1 If no part number is listed, adaptor is not supplied by Parker. In most cases, customer can assemble adaptor from standard pipe fittings. Refer to pages 141-142.

2 Multiple filters piped in parallel are required.

3 Requires 1 1/2" Male x 1" Female reducing bushing supplied by customer.

4 Requires 3" Male x 1 1/2" Female reducing bushing supplied by customer.

5 Requires 2" Male x 1 1/2" Female reducing bushing supplied by customer.

# Vacuum Pump Inlet & Exhaust Filters

## Recommended Exhaust Filters for Vacuum Pumps

Vacuum  
Pump Filters

Pump Model No.	Pump Rating CFM (m <sup>3</sup> /hr) (Free Air)	Pump Exhaust (NPT Female Unless Otherwise Noted)	Recommended Balston Filter Non-Hazardous Non-Corrosive Applications	Balston Anodized Aluminum Pump-To-Filter Adaptor (1)	Recommended Balston Filter Hazardous and Corrosive Applications	Balston Stainless Steel Pump-To-Filter Adaptor (1)
<b>Rietschle Pumps</b>						
VAL/VL/VE 10	6.8 (12)	NW 25	R-009	14173	CV-0118	14182
VF/VFE/CLFG 11	6.8 (12)	1/2"	R-009		CV-0118	
VF/VFE 16	10.2 (17)	1/2"	R-015			
CLFG/CLF/CLFE 16	10.2 (17)	1/2"	R-015			
VAL/VL/VLV 25	16.9 (29)	NW 25	AR-0316	14173		
VF/VFE 26	16.9 (29)	3/4"	AR-0316			
CLFG/CLF/CLFE 26	16.9 (29)	3/4"	AR-0316			
VL/VLV 40	30 (51)	NW 25	AR-0335	14183		
VF/VFE 41	27 (46)	3/4"	AR-0335			
CLFG/CLF/CLFE 41	27 (46)	3/4"	AR-0335			
VL/VLV 60	40 (68)	3/4"	AR-0335			
VF/VFE 61	40 (68)	3/4"	AR-0335			
CLFG/CLF/CLFE 61	40 (68)	3/4"	AR-0335			
VL/VLV 80	54 (92)	NW 40	AR-0735	14174 (4)		
VF/VFE 81	54 (92)	1"	AR-0735			
CLFG/CLF/CLFE 81	54 (92)	1"	AR-0735			
VL/VLV 100	67 (114)	NW 40	AR-0735	14174 (4)		
VF/VFE 101	67 (114)	1 1/4"	AR-0735			
CLFG/CLF/CLFE 101	67 (114)	1 1/4"	AR-0735			
VWZ 102	67 (114)	NW 65	AR-0735			
CLF/CLFE 141	94 (160)	1 1/2"	AR-0735			
VFH/VFEH 161	108 (183)	2"	AR-0780			
VWZ 162	108 (183)	NW 65	AR-0780			
CLF/CLFE 181	108 (183)	2"	AR-0780			
VWZ 252	169 (287)	NW 65	AR-0780			
CLFH/CLFEH 341	230 (391)	3"	AR-1280			
VWZ 402	270 (459)	NW 65	AR-1280			
CLFH/CLFEH 501	338 (574)	3"	AR-1680			
CLFH/CLFEH 631	426 (724)	3"	AR-1680			
CLFH/CLFEH 1001	677 (1150)	3"	AR-3080			
VLV25-2	18 (31)	3/4" NPT	AR-0316			
VLV25-3	18 (31)		AR-0316			
VLV40-2	28 (48)	3/4" NPT	AR-0335			
VLV40-3	28 (48)		AR-0335			
VWZ702	494 (839)		AR-3080			
VWZ1002	706 (1199)		AR-3080			
VGD10	7 (12)		R-009		CV-0118	
VGD15	11 (19)		R-015			
VCE15	11 (2)	1/2" NPT	R-015			
VCE25	18 (31)	3/4" NPT	AR-0316			
VCE40	28 (48)	1" NPT	AR-0335			
VC50	35 (59)	1-1/4" NPT	AR-0335			
VCE60	42 (71)	1" NPT	AR-0335			
VC75	49 (83)	1-1/4" NPT	AR-0735			
VC100	71 (121)	1-1/2" NPT	AR-0735			
VC150	105 (178)	1-1/2" NPT	AR-0780			
VC200	141 (240)	2" NPT	AR-0780			
VC300	212 (360)	2" NPT	AR-1280			
VC400	282 (479)	3" NPT	AR-1280			
VC500	388 (659)	3" NPT	AR-1680			
VC700	494 (839)	3" NPT	AR-3080			
VC900	636 (1081)	4" NPT	AR-3080			
VC1100	777 (1320)	4" NPT	AR-3080			
VC1300	918 (1560)	4" NPT				
VLR100	72 (122)	1-1/2" NPT	AR-0735			
VLR250	166 (282)	2" NPT	AR-0780			
VL5300	212 (360)	2" NPT	AR-1280			
VLR400	272 (462)	3" NPT	AR-1280			
VLR500	353 (600)	3" NPT	AR-1680			

**Notes:**

1 If no part number is listed, adaptor is not supplied by Parker. In most cases, customer can assemble adaptor from standard pipe fittings. Refer to pages 141-142.

2 Multiple filters piped in parallel are required.

3 Requires 1 1/2" Male x 1" Female reducing bushing supplied by customer.

4 Requires 3" Male x 1 1/2" Female reducing bushing supplied by customer.

5 Requires 2" Male x 1 1/2" Female reducing bushing supplied by customer.

Pump Model No.	Pump Rating CFM (m <sup>3</sup> /hr) (Free Air)	Recommended Pump Exhaust (NPT Female Unless Otherwise Noted)	Balston Filter Non-Hazardous Non-Corrosive Applications	Recommended Balston Anodized Aluminum Pump-To-Filter Adaptor (1)	Balston Filter Hazardous and Corrosive Applications	Balston Stainless Steel Pump-To-Filter Adaptor (1)
<b>RO-FLO Pumps (Allis-Chalmers)</b>						
5CCA	55 (93)	1 1/2"	AR-0735			
5CCB	86 (86)	1 1/2"	AR-0735			
7DB	151 (151)	3"AR-0780				
7DC	235 (235)	3"AR-1280				
8DB	275 (275)	3"AR-1280				
8DE	345 (345)	3"AR-1680				
10GB	411 (411)	4"AR-1680				
10GC	593 (593)	4"AR-3080				
11S	738 (738)	5"AR-3080				
11L	838 (838)	5"AR-3080				
12S	970 (970)	6"AR-3080 (2)				
12L	1080 (1080)	6"AR-3080 (2)				
17S	1228 (1228)	6"AR-3080 (2)				
17L	1420 (1420)	6"AR-3080 (2)				
19S	1693 (1693)	8"AR-3080 (2)				
19L	1920 (1920)	8"AR-3080 (2)				
23C	2270 (2270)	8"AR-3080 (2)				
23D	2740 (2740)	8"AR-3080 (2)				
27D	3300 (3300)	10"	AR-3080 (2)			
33D	5950 (10109)	14"	AR-3080 (2)			
<b>Sargent-Welch Pumps</b>						
1373	10.6 (19)	1-20	R-015	14163		
1374	23 (39)	1-3/4-20	AR-0335	14164		
1375	35 (59)	Square Flange	AR-0335			
1376	10.6 (18)	1-20	R-015 (3)	14163		
1380	5.6 (10)	1-20	R-009	14162	CV-0118	
1392	0.9 (1.5)	3/4-20	9955-12	14165	CV-0112	
1395	71 (121)	Square Flange	AR-0735			
1396	100 (170)	Square Flange	AR-0735			
1397	17.7 (30)	1-3/4-20	AR-0316	14160		
1398	53 (90)	Square Flange	AR-0735			
1399	1.2 (2.1)	3/4-20	9955-12	14165	CV-0112	
1400	0.9 (1.5)	3/4-20	9955-12	14165	CV-0112	
1402	5.6 (10)	1-20	R-009	14162	CV-0118	
1403	3.5 (5.9)	1-20	R-009	14162	CV-0118	
1405	2.1 (3.6)	3/4-20	9955-12	14165	CV-0112	
1410	0.7 (1.2)	1/2" Hose	9955-12		CV-0112	
8802	0.9 (1.5)	3/4-20	9955-12	14165	CV-0112	
8803B/8804B	0.9 (1.5)	3/4-20	9955-12	14165	CV-0112	
8803K/8804K	0.7 (1.2)	3/4-20	9955-12	14165	CV-0112	
8805	1.8 (3.1)	1-20	9955-12	14166	CV-0112	
8806B/K	1.8 (3.1)	NW 25	9955-12	14175	CV-0112	14182
8810	3.5 (5.9)	1-20	9955-12	14166	CV-0118	
8811B	3.5 (5.9)	NW 25	R-009	14173	CV-0118	14182
8811K	2.9 (4.9)	NW 25	9955-12	14175	CV-0112	14182
8814	5.6 (10)	NW 25	R-009	14173	CV-0112	14182
8815	5.3 (9.0)	1-20	R-009	14162	CV-0118	
8816B/K	5.3 (9.0)	NW 25	R-009	14173	CV-0118	14182
8821	7.4 (13)	NW 25	R-009	14173	CV-0118	14182
8830	10.6 (18)	1-3/4-20	R-015	14160		
8834	12 (20)	NW 40	R-015	14174		
8851	18 (31)	NW 40	AR-0316	14174		
8861	35.3 (60)	NW 50	AR-0335			
8871	53 (90)	NW 50	AR-0735			
8890	7.7 (13)	3/4-20	R-009	14173	CV-0118	14182
8905	1.8 (3.1)	NW 16	9956-12		CV-0112	14181
8910	3.8 (6.5)	NW 16	R-009	14172	CV-0118	14181 (4)
8910A	3.1 (5.3)	NW 16	R-009	14172	CV-0118	14181 (4)
8915	5.6 (10)	1-20	R-009	14162	CV-0118	
8920	7.7 (13)	NW 25	R-009	14173	CV-0118	14182

Notes:

- 1 If no part number is listed, adaptor is not supplied by Parker. In most cases, customer can assemble adaptor from standard pipe fittings. Refer to pages 141-142.
- 2 Multiple filters piped in parallel are required.
- 3 Consult factory for piping considerations.
- 4 Requires 3/4" male x 1/2" female reducing bushing supplied by customer.

# Vacuum Pump Inlet & Exhaust Filters

## Recommended Exhaust Filters for Vacuum Pumps

Vacuum  
Pump Filters

Pump Model No.	Pump Rating CFM (m <sup>3</sup> /hr) (Free Air)	Pump Exhaust (NPT Female Unless Otherwise Noted)	Recommended Balston Filter Non-Hazardous Non-Corrosive Applications	Balston Anodized Aluminum Pump-To-Filter Adaptor (1)	Recommended Balston Filter Hazardous and Corrosive Applications	Balston Stainless Steel Pump-To-Filter Adaptor (1)
<b>Stokes Pumps</b>						
V-005	7 (12)	NW 25	R-009	14173	CV-0118	14182
V-009	11 (19)	NW 25	R-015	14173		
V-013-2	20 (34)	NW 40	AR-0316	14174		
V-017-2	36.7 (62)	NW 40	AR-0335	14174		
V-23	55 (93)	NW 40	AR-0735	14174 (3)		
146H	30 (51)	1 1/4"	AR-0335			
148H	50 (85)	1 1/2"	AR-0735			
149H	80 (136)	1 1/2"	AR-0735			
149HS	100 (170)	1 1/2"	AR-0735			
212HS	150 (255)	2"	AR-0780			
412H	300 (510)	3"	AR-1280			
612H	600 (1019)	3"	AR-3080			
912H	728 (1237)	5"	AR-3080			
212J	150 (255)	" NPT	AR-0780			
412J	300 (510)	3" NPT	AR-1280			
612J	600 (1019)	3" NPT	AR-3080			
<b>Ulvac Pumps</b>						
G-5	0.21 (0.4)	M17 x 1	9955-12		CV-0112	
G-15	0.63 (1.1)	3/4"	9955-12		CV-0112	
G/GC-25S	0.84 (1.4)	3/4"	9955-12		CV-0112	
G/GC-20D	0.84 (1.4)	3/4"	9955-12		CV-0112	
G-50S/D	2.1 (3.6)	3/4"	9955-12		CV-0112	
GC-50D	2.1 (3.6)	3/4"	9955-12		CV-0112	
G-100S/D	4.2 (7.1)	1"	R-009		CV-0118	
GC-100D	4.2 (7.1)	1"	R-009		CV-0118	
GVD-050	2.1 (3.6)	3/4"	9955-12		CV-0112	
GVD-100	5.6 (10)	1"	R-009		CV-0118	
GVD-165	7 (12)	3/4"	R-009		CV-0118	
DA-30S	1.1 (1.9)	3/4"	9955-12		CV-0112	
DA-60S	2.5 (4.2)	3/4"	9955-12		CV-0112	
D-330D	9 (15)	1 1/2"	R-009		CV-0118	
D-650D	18 (31)	1 1/2"	AR-0316			
D-950D	27 (46)	2"	AR-0335			
PKS-016	57 (97)	2"	AR-0735			
PKS-030	107 (182)	3"	AR-0780			
PKS-070	250 (425)	4"	AR-1280			
PVD-180	6.4 (11)	3/4"	R-009		CV-0118	
PDV-360	13 (22)	1"	R-015			
<b>Varian Pumps</b>						
CS/SS/SD-90	3.2 (5.4)	NW 25	R-009	14173	CV-0118	14182
EVAC 200	7 (12)	3/4"	R-009		CV-0118	
EVAC 300	11 (19)	3/4"	R-015			
CD/SD-200	7 (12)	NW 25	R-009	14173	CV-0118	14182
CD/SS/SD-300	11 (19)	NW 25	R-015	14173		
CD/SS/SD-700	27 (46)	NW 40	AR-0335	14174		
CD/SS/SD-1400	50 (85)	NW 40	AR-0735	14173 (3)		
CD/SD-2500	90 (153)	NW 50	AR-0735			

Notes:

1 If no part number is listed, adaptor is not supplied by Parker. In most cases, customer can assemble adaptor from standard pipe fittings. Refer to pages 141-142.

2 Multiple filters piped in parallel are required.

3 Requires 3" Male x 1 1/2" Female reducing bushing supplied by customer.

4 Requires 2" Male x 1 1/2" Female reducing bushing supplied by customer.



# Vacuum Pump Inlet & Exhaust Filters

## Pump to Filter Adaptors - Straight Thread to NPT Thread

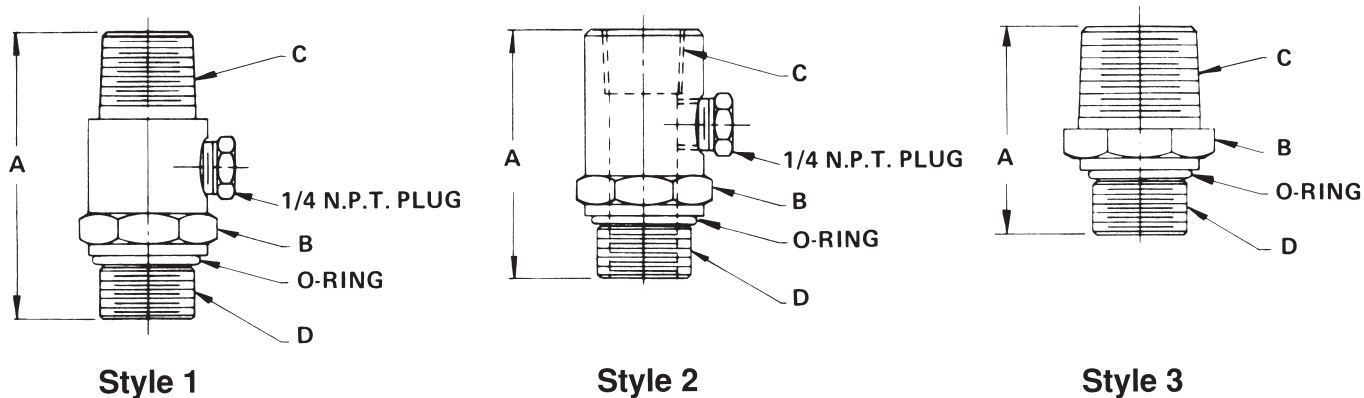

Vacuum  
Pump Filters

### Principal Specifications

Type	Adaptor Style	Materials of Construction		Dimensions Inches (cm)			
		Adaptor	Seals	(A) Height	(B) Hex Size	(C) NPT Thread	(D) Thread
14168	1	Alum.	Buna-N	3.0 (7.62)	1.25	3/4	M24 x 1
14166	2	↓	↓	2.6 (6.60)	↓	1/2 F (1)	1-20
14165	2			2.44 (6.20)		1/2 F (1)	3/4-20
14164	3			2.88 (7.32)	2.0	1 1/2	1 3/4-20
14163	3			2.19 (5.56)	1.38	1	1-20
14162	1			3.0 (7.62)	1.25	3/4	1-20
14160	3			2.3 (5.84)	2.0	1	1 3/4-20
14159	1			3.15 (8.00)	1.25	3/4	3/4 BSPT (2)
14158	2			2.80 (7.11)	↓	1/2 F (1)	3/4 BSPT (2)
14157	2			2.56 (6.50)		1/2 F (1)	3/8 BSPT (2)

Notes:

1 Female NPT - all others Male.

2 O-ring not supplied on adaptors with tapered threads.